

FRONT VIEW

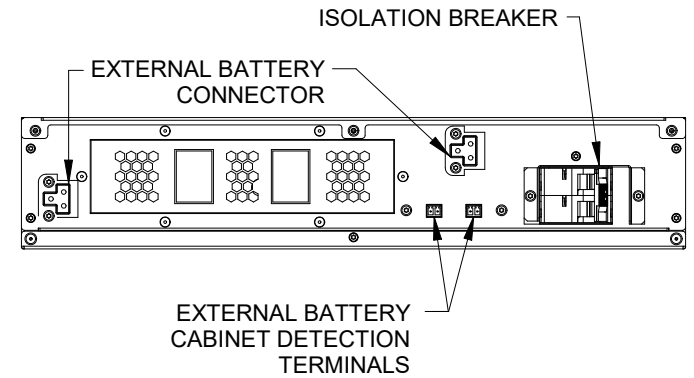

REAR VIEW

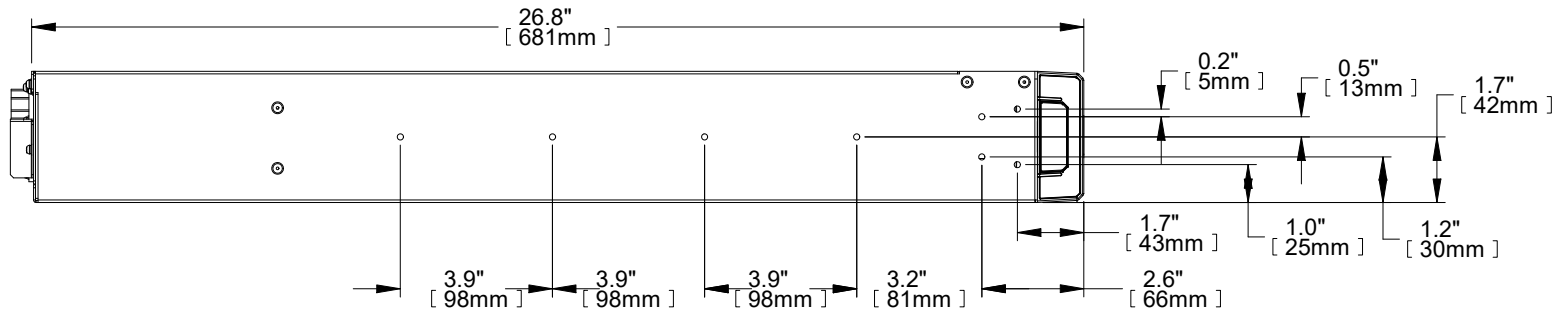

SIDE VIEW

NOTES:

1. UNIT DIMENSIONS (WxDxH): 16.9" x 26.8" x 3.3" (2U)
(430mm) x (681mm) x (85mm)
2. UNIT WEIGHT: 81.6lbs (37kg)
3. SHIPPING DIMENSIONS (WxDxH): 35.5" x 25.7" x 19.8"
(845mm) x (630mm) x (485mm)
4. SHIPPING WEIGHT: 123.5lbs (56kg)
5. MINIMUM AIRFLOW CLEARANCE IS 4.0" (100mm) FRONT AND REAR.

DRAWN BY B. LAY	SHEET NO. 1 OF 1
CHK BY M. MCCLINCY	ECN NO.
REF. DWG.	ORDER NO.

OUTLINE DRAWING
LIEBERT GXT5
144V EXTERNAL BATTERY CABINET

DWG. NO. GXT5-144VEBC OD	DATE 1/30/19	REV. # 0	1050 DEARBORN DRIVE P.O. BOX 29186 COLUMBUS, OHIO 43229
-----------------------------	-----------------	-------------	---

